



SHADOWCLAD® STAINLESS STEEL FLASHING UPDATE

Carter Holt Harvey Woodproducts (CHHWP) is dedicated to the continual development and improvement of its building systems. As part of this continual development, CHHWP has made some practical improvements to the Stainless Steel Horizontal “Z” Flashings and Inter-Storey “Z” Flashings.

Shadowclad is BRANZ appraised for both direct fixed and cavity-based wall cladding systems consisting of Shadowclad Panels, Shadowclad Flashings and accessories. This Information Bulletin should be read in conjunction with the latest version of the Shadowclad Specification and Installation Guide for Cavity Construction or Direct Fix Cladding as applicable.

Figure 1 - Horizontal 'Z' Flashing

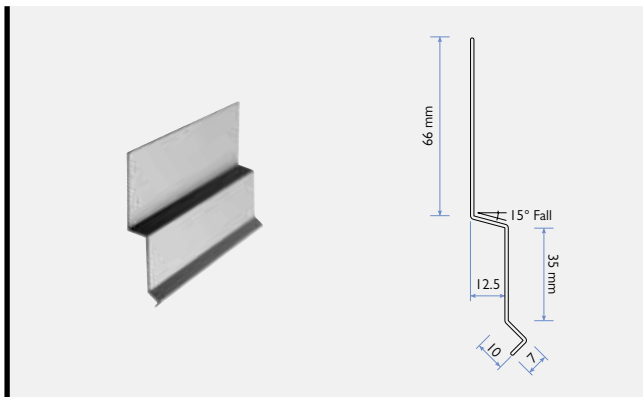

SHADOWCLAD® STAINLESS STEEL FLASHING RANGE CHANGES

The Shadowclad Stainless Steel Flashing Range was developed in accordance with the design principles of E2/AS1 using increased upstands and hems to meet these requirements. Some builders have found the hems influence the vertical plane of the Shadowclad Panel. In light of this CHHWP reviewed the E2/VM1 verification method testing of our aluminium horizontal 'z' flashings with a 50 mm upstand and the applicability of the hem relative to the overall flashing profile. It was concluded, in consultation with BRANZ, that the successful E2/VM1 testing for Shadowclad incorporated flashings without hems.

Based on this, CHH Woodproducts will now be supplying both the Stainless Steel Horizontal 'Z' flashing and Horizontal Inter-storey 'Z' flashing with a 66mm upstand excluding hems as detailed in Figures 1 and 2. Our Shadowclad Specification and Installation Guides will be updated in due course. Our Shadowclad Stainless Steel horizontal flashing range is still available including hems, however additional lead times may apply.

Figure 2 - Inter-Storey 'Z' Flashing

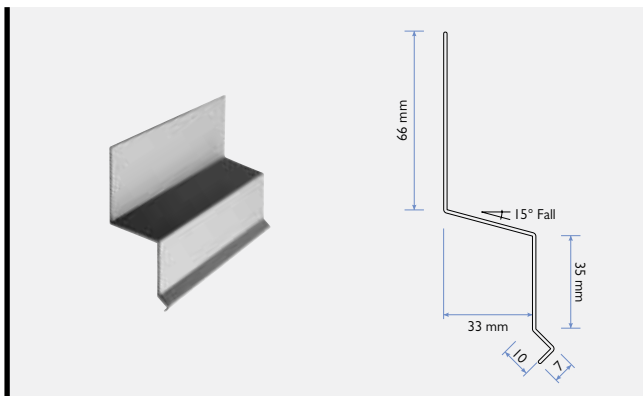

COMPLIANCE

The Shadowclad Horizontal 'Z' flashing and Horizontal Inter-storey 'Z' flashing and associated details, as an Alternative Solution, have been appraised by BRANZ as meeting the relevant performance requirements of NZBC Clause E2.

For further information contact Customer Services on 0800 326 759 or visit www.chhwoodproducts.co.nz.